

# KF SERIES



## Description

The Solahart Kf Series is a roof mounted, closed circuit system specifically designed to provide the ultimate efficiency for use in low to medium solar gain areas.

The ultra-high efficiency absorber with its Black Chrome Selective Surface maximises the absorption of available solar energy while the closed circuit design makes it suitable for frost prone or harsh water areas.

The Kf Series features Solahart's revolutionary multi-flow collector panel which uses a huge 35 risers to extract the maximum amount of energy from the sun.

The double ceramic lined tank, with its protective anode, has been developed for long life and the Kf Free Heat features additional protection for longer lasting performance. The tank can be equipped with an electric or gas booster, alternatively an in-line gas booster is available.

## Key Features

- Highly efficient Black Chrome Selective Surface collector for optimum heat absorption
- Multi-flow closed circuit operation makes it suitable for frost prone or harsh water areas
- Stylish slimline design
- Thermosiphon operation minimises maintenance - no moving parts
- Two gas boost options or electric booster models available
- Double coated ceramic lined tank for long life
- Enhanced protection on Free Heat model for maximum life

## Key Benefits

- Save 60% to 90% of your water heating energy consumption\*
- Reliable, low maintenance operation
- Hot water regardless of the weather
- Can qualify for valuable government environmental incentives\*
- Reduced energy use saves up to 3.7 tonnes of CO<sub>2</sub> emissions every year\*
- Peace of mind with 10/5/5<sup>†</sup> (Kf Free Heat) and 5/5/5<sup>†</sup> (Kf Series) year warranties

\*Savings of 60% - 90% shown are based on Australian Government approved TRNSYS simulation modelling. Savings and incentives will vary depending upon your location, type of Solahart system installed, orientation and inclination of the solar collectors, type of water heater being replaced, hot water consumption and fuel tariff. Maximum financial savings off your hot water bill are achievable when replacing an electric water heater on continuous tariff.

<sup>†</sup>Warranty Details: 10/5/5, 10 year cylinder and collectors, 5 year parts, 5 year labour; 5/5/5, 5 year cylinder and collectors, 5 year parts, 5 year labour; applies to a single family domestic dwelling only. All other applications have either a 5/1/1/1 (Free Heat) or 3/1/1/1, 5 or 3 years cylinder, 1 year collectors, 1 year parts, 1 year labour.

# Thermosiphon Kf and Kf Free Heat Closed Circuit Systems

These systems are suitable for multiple installations. They are suitable for frost and harsh water regions.

## Kf and Kf Free Heat Systems

Model		150 tank	151 system	180 tank	181 system	182 system	220 tank	221 system	222 system	300 tank	301 system	302 system	303 system	440 tank	443 system	444 system
Tank model																
Kf		150J	✓	180J	✓	✓	220J	✓	✓	300J	✓	✓	✓	440J	✓	✓
Kf Free Heat		150F		180F	✓	✓	220F	✓	✓	300F		✓	✓	440F	✓	✓
Collector model			Kf		Kf	Kf		Kf	Kf		Kf	Kf	Kf		Kf	Kf
No of collectors			1		1	2		1	2		1	2	3		3	4
Storage capacity	litres	150	150	180	180	180	220	220	220	300	300	300	300	440	440	440
	US gal	40	40	48	48	48	58	58	58	80	80	80	80	116	116	116
Delivery capacity (solar)	litres	130	130	160	160	160	200	200	200	240	240	240	240	400	400	400
	US gal	34	34	42	42	42	53	53	53	63	63	63	63	106	106	106
Boost capacity (electric or gas)	litres	75	75	90	90	90	110	110	110	150	150	150	150	220	220	220
	US gal	20	20	24	24	24	29	29	29	40	40	40	40	58	58	58
Weight empty	kg	56	102	66	108	154	78	124	170	99	145	187	229	148	290	320
	lbs	123	225	146	238	340	172	273	375	218	320	412	505	326	639	705
Weight full	kg	206	256	245	292	338	298	348	394	399	449	495	541	588	730	776
	lbs	454	564	540	644	745	657	767	869	880	990	1091	1193	1296	1609	1711
A - Width	m	1.40	1.40	1.62	1.62	2.42	1.88	2.04	2.42	2.43	2.43	2.43	3.38	3.41	3.49	4.44
	in	55.1	55.1	63.8	63.8	95.3	74.0	80.3	95.3	95.7	95.7	95.7	133.1	134.3	137.4	174.8
B - Length	m	0.51	2.48	0.51	2.48	2.48	0.51	1.64	2.48	0.51	1.64	2.48	2.48	0.51	2.48	2.48
	in	20.1	97.6	20.1	97.6	97.6	20.1	64.6	97.6	20.1	64.6	97.6	97.6	20.1	97.6	97.6

The Kf and Kf Free Heat systems can be installed as a solar preheater with an in-line Solahart gas booster water heater. Refer to the Solahart gas booster specification sheet for further details on the gas booster.

### Kf Collector

Aperture (heating) area	m <sup>2</sup>	1.87	ft <sup>2</sup>	20	
Dimensions	length	mm	1937	in	76.3
	width	mm	1022	in	40.3
	height	mm	77	in	3.0
Capacity	litres	3.5	US gal	0.9	
Weight	empty	kg	42	lbs	93
	full	kg	46	lbs	101
Working pressure	kPa	80	psi	12	
Absorber surface	Chromonyx selective surface				
Absorber material	steel				
Riser material	steel				
Number of risers	35				
Tray material	0.6 mm aluminium				
Insulation material	55 mm glass wool blanket				
Glass	3.2 mm tempered low iron				

### Kf and Kf Free Heat

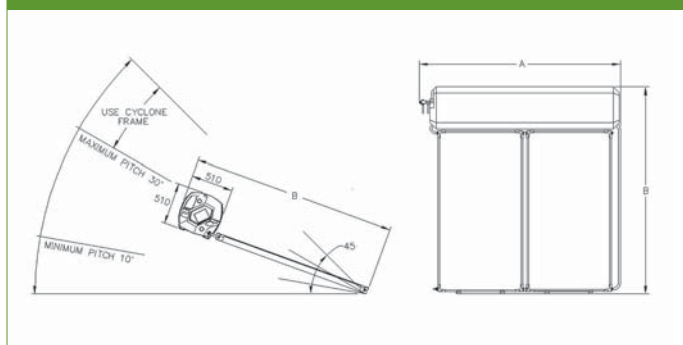

### Electric Boost Specifications

Heating unit type*	Copper sheath immersion element			
Supply voltage	220 V – 250 V			
Recovery rate @ 240 V and temperature rise of:				
Rating kW	Current Amps	40°C litres	50°C litres	60°C litres
1.8	8	39	31	26
2.4	10	52	41	34
3.0	13	64	52	43
3.6	15	77	62	52
4.8	20	103	83	69

\*A bobbin element (2.5 kW) is available for hard or corrosive water areas.

### Gas Boost (In Tank - Optional) Specifications

Model type*	FD15 gas booster fan forced
Burner rating - Input/Output	13 MJ/h / 10 MJ/h (2.8kW)
Recovery rate	59 litres per hour @ 40°C rise
Primary voltage	220 V – 250 V
Secondary voltage	12 V DC

\*Suitable for hard or corrosive water areas.

### Water Supply

TPR valve setting	kPa	1000	psi	145
ECV* setting	kPa	850	psi	125
Max. supply pressure with ECV	kPa	680	psi	100
	kPa	800	psi	115
Water Connections	cold	RP ¾ / 20		
	hot	R ½ / 15		

\*Expansion Control Valve.